

Network-Controlled High Voltage Power Supply Working in Magnetic Field

By

Hiroshi MATSUMOTO, Masatosi IMORI, Yoshiaki SHIKAZE¹, Hideyuki FUKU²,
and Takashi TANIGUCHI³

Abstract : This article describes a network of high voltage power supplies which are controlled and managed through a network. The high voltage power supply incorporates a ceramic transformer which utilizes piezoelectric effect to generate high voltage. The ceramic transformer is constructed from a ceramic bar and does not include any magnetic material. A high voltage power supply can work without a loss of efficiency under a magnetic field of 1.5 tesla. The power supply includes feedback to stabilize the high voltage output, supplying from 2000V to 4000V with a load of more than 10 M Ω at efficiency higher than 60 percent.

The high voltage power supply includes a Neuron chip*, a programming device processing a variety of input and output capabilities. The chip can also communicate with other Neuron chips over a twisted-pair cable, which allows establishing a high voltage control network consisting of a number of power supplies that incorporate the chip individually. The functions of the power supply under the control of the chip are managed through the network. The chip turns on and off the high voltage power supply and sets the output high voltage. The chip detects the short circuit of the output high voltage and controls its recovery. The chip also monitors the output current. Thus the high voltage power supplies are monitored and controlled through the network.

Key words : high voltage power supply, piezoelectric ceramic transformer, magnetic field, network

International Center for Elementary Particle Physics, University of Tokyo, 7-3-1 Hongo, Bunkyo-ku, Tokyo 113, Japan

¹Faculty of Science, Kobe University, 1-1 Rokko-dai, Nada-ku, Kobe 657, Japan

²Faculty of Science, Department of Physics, University of Tokyo, 7-3-1 Hongo, Bunkyo-ku, Tokyo 113, Japan

³National Laboratory for High Energy Physics (KEK) 1-1 Oho, Tsukuba-shi, Ibaraki-ken 305, Japan

1. Introduction

A large-scale measurement apparatus for an elementary particle experiment consists of many detectors. Many of detectors used for this kind of the apparatus need high voltage power supplies. The demand to a high voltage power supply changes with detectors. A single detector utilizes thousands to 100,000 of the high voltage power supplies. So far the high voltage power supplies, located far from the apparatus, supply high voltages to the detectors through long high voltage cables because of the magnetic field applied in the apparatus. If a high voltage power supply operating under a magnetic field is available, a high voltage cable will become unnecessary. A high voltage power supply incorporated into the apparatus will be an epoch-making advance in the instrumentation of an elementary particle experiment.

BESS is a balloon-borne experiment. A superconducting solenoid generating a magnetic flux density of 1.2 tesla is integrated to the balloon-borne apparatus. In the balloon-borne experiment, reduction of weight is important and the return yoke which shuts up the magnetic flux is omitted. As a result, the magnetic flux generated by the solenoid has spread to the space around the payload. About 100 photomultipliers are used in the BESS apparatus. In order to realize a fixed gain of amplification, the photomultipliers are required to be supplied with high voltages which are individually different among the photomultipliers. So in the BESS experiment it is inevitable to place these high voltage power supplies in the magnetic field. The BESS experiment is in need of the lightweight high voltage power supplies operating efficiently under a magnetic field.

For these reasons, we have tried the development and utilization of a high voltage power supply using the ceramic transformer. So far, it is confirmed that the high voltage power supply generates the high voltage efficiently with high stability and sufficient accuracy. Moreover, it is shown as a result of the test under a magnetic field of 1.5 tesla that the high voltage power supply operates independent of a magnetic field. Magnetic material is not used for the high voltage power supply. That is, the high voltage power supply is not influenced by a magnetic field theoretically. Therefore, it is expected that the high voltage power supply operates also under a magnetic field of several tesla.

A large number of high voltage power supplies are employed in a measurement apparatus for an elementary particle experiment. It is required to control these high voltage power supplies systematically and flexibly. It is possible to realize such the control of the power supply without adding intelligence to the high voltage power supply. For example, by connecting the high voltage power supplies to the I/O bus of a control computer as input/output devices, the control computer can control the power supplies as I/O devices. In reality, the number of signal lines in the bus is too large to connect the power supplies scattered in a wide area. In this sense, it is practical to add such intelligence to each high voltage power supply that the control computer can communicate with the high voltage power supplies by a reduced number of the signal lines. Adding intelligence further to the high voltage power supply leads to networking the high voltage power supplies, where the high voltage power supply operates as a node of the network. Neuron chips implement LonWorks** nodes, which are networked by a LonWorks network. The chip can communicate with other Neuron chips over a twisted-pair cable, which allows establishing a network. The chip processes a variety of input and output capabilities, which facilitates the control of a dumb device. Thus the Neuron chip provides the intelligence to make the dumb device to be networked intelligently. The high voltage power supply is kept under the control of the Neuron chip, which enables the power supplies to be networked intelligently.

2. High Voltage Power Supply

The high voltage power supply includes feedback to stabilize the high voltage output, supplying from 2000V to

** LonWorks is a registered trademark of Echelon Corporation.

4000V with a load of more than 10 MΩ at efficiency higher than 60 percent under a magnetic field of 1.5 tesla. The high voltage power supply incorporates a ceramic transformer. The ceramic transformer takes the place of the conventional magnetic transformer. The ceramic transformer utilizes piezoelectric effect to generate high voltage. The ceramic transformer is constructed from a ceramic bar and does not include any magnetic material. So the transformer is free of leakage of magnetic flux and can be operated efficiently under a magnetic field. The transformer employed in the high voltage supply, manufactured by NEC Corporation, is a small, low-profile, highly efficient piezoelectric ceramic transformer. The transformer is shaped symmetrically in the lengthwise direction and operated in the third order longitudinal vibration mode. The maximum power rating of the ceramic transformer is about 4 W.

2. 1. Feedback

The output high voltage supply is composed of divider resistors, an error amplifier, a voltage controlled oscillator (VCO), a driver circuit, the ceramic transformer and a Cockcroft-Walton (CW) circuit (Fig. 1). The VCO generates a driving frequency of a sinusoidal voltage wave which drives the ceramic transformer. The VCO supplies the driving frequency to the driver circuit where the sinusoidal voltage wave is generated synchronized with the driving frequency. The sinusoidal voltage wave is amplified in voltage by the transformer and then supplied to a Cockcroft-Walton (CW) circuit where the sinusoidal wave is amplified further in voltage and rectified. An output high voltage is produced at the output of the CW circuit.

The output high voltage is stabilized by feedback. The output voltage is divided by the divider resistors and fed to the error amplifier to be compared with a reference voltage. The output of the error amplifier is supplied to the VCO which generates the driving frequency of the sinusoidal voltage wave. The sinusoidal voltage wave drives the transformer through the driver circuit. Voltage amplification of the transformer depends on the frequency of the sinusoidal voltage wave. The driving frequency generated by the VCO is controlled by the output of the error amplifier. So magnitude of the amplification is adjusted by controlling the driving frequency, which stabilizes the output high voltage.

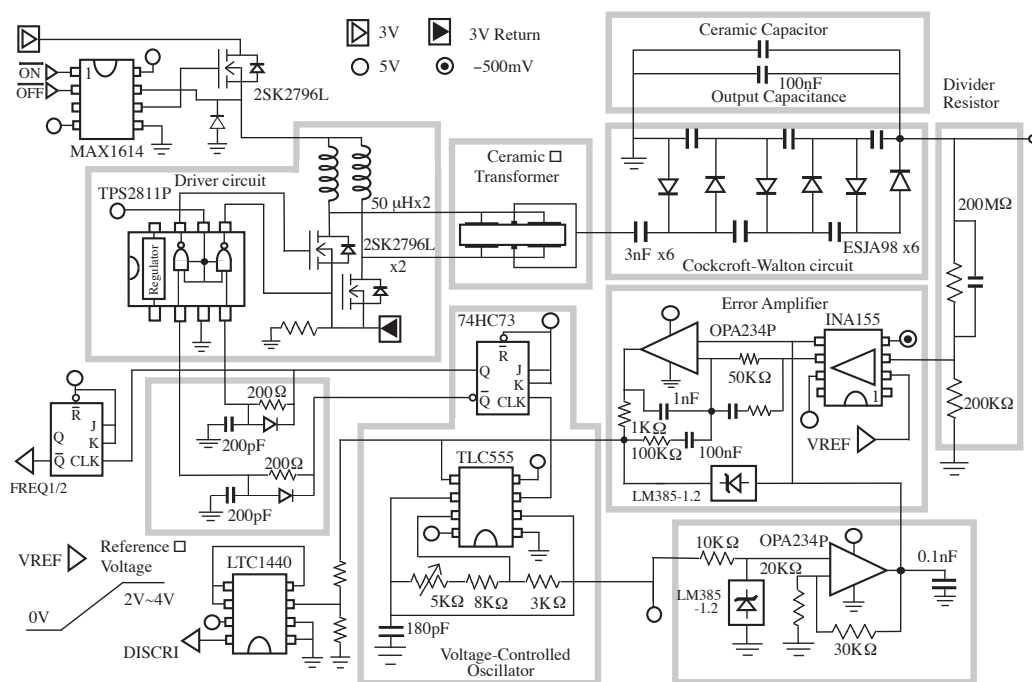

Fig1 Schematic circuit of high voltage power supply

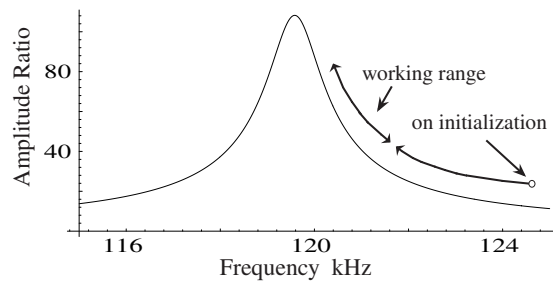

Fig2 Resonance shown by transformer

The ceramic transformer includes an internal resonance circuit. The transformer input voltage is amplified at the output, with the input to output voltage ratio being an amplitude ratio that shows a resonance as a function of the driving frequency. The resonance is shown in Fig. 2. The range of the driving frequency is designed to be higher than a resonance frequency of the ceramic transformer. As shown in Fig. 2, the feedback increases the driving frequency when the output voltage is higher than the reference voltage at the input of the error amplifier. Similarly, the driving frequency decreases when output voltage is lower than the voltage specified by the reference voltage.

The transfer function of the error amplifier includes a zero at the origin, by which a magnitude of feedback is increased at low frequencies. So even when the load is changed from 20 M Ω to 5 M Ω , the output high voltage is kept fixed except for a transition time.

2. 2. Breakdown of Feedback

If the load of the high voltage power supply falls within an allowable range, the driving frequency is maintained higher than the resonance frequency such that the feedback is negative as designed. The allowable range of load is sufficient in most cases, but it cannot cover, for example, short-circuiting the output high voltage to ground. When the load deviates beyond the allowable range, the driving frequency may decrease below the resonance frequency; a condition that will not provide the required negative feedback, i.e., positive feedback locks the circuit such that it is independent of load. In order to recover the negative feedback, the driving frequency must be reset externally in addition to removing the load.

3. 3. Circuit Protection

An unallowable range of load may flip the frequency of the VCO beyond the resonance frequency. The flip of the frequency, accompanied with the breakdown of the feedback, lowers the output high voltage. Thus the flip of the frequency works as protection against, for example, a short circuit of output high voltage.

3. Network

Neuron chips enable dumb electrical devices to network intelligently. Neuron chips have all the built-in communications and control functions to implement LonWorks nodes. These nodes may be easily integrated into highly-reliable distributed intelligent control networks called LonWorks network. The LonTalk^{***} protocol used in LonWorks networks is a layered, packet-based, peer-to-peer communication protocol. The protocol complies with the reference model for open systems interconnection (OSI) developed by the International Standard Organization (ISO). The LonTalk protocol is designed to fulfill the requirements of a variety of control applications. Each packet is a variable number of bytes in length and contains the application level information together with addressing and other network information. Every Neuron chip looks at every packet transmitted to the media to determine if it is an addressee. If so, the Neuron chip processes the packet to see if the packet contains data for the application program

^{***}LonTalk is a registered trademark of Echelon Corporation.

or whether it is a network management packet. The application data in the packet is provided to the application program.

3.1. Neuron Chip

In reference to the ISO model of a communication protocol, the Neuron chips provides up to sixth layers. Only application layer program and configuration needs to be coded, which simplifies implementation and makes development and configuration easy. The Neuron chip is a system-on-a-chip with multiple microprocessors, read-write and read-only memory (RAM and ROM), a media-independent network communication port and a configurable I/O controller. The read-only memory contains an operating system, the LonTalk communication protocol, and an I/O function library. A complete implementation of the LonTalk protocol is contained in ROM in every Neuron chip. The chip has non-volatile RAM for configuration data and for the application program, both of which are downloaded over the network.

The I/O controller provides two timer/counters and configurable 11 I/O pins that can interface with a variety of sensors, actuators and convertors. Each Neuron chip contains three 8-bit CPUs. Two of the CPUs handle LonWorks protocol communication, and the third run an application. The Neuron chip can communicate with other Neuron chips over a twisted-pair cable; a feature that allows establishing a network of the Neuron chip. The peer-to-peer protocol for communication allows all the Neuron chip connected to the network to communicate with each other.

3.2. Node for High Voltage Power Supply

A LonWorks node including the Neuron chip integrates a communication transceiver, clock and reset circuitry. The Neuron chip provides the control, communications and I/O control. The high voltage power supply works as a LonWorks node. A circuit diagram of the node is shown in Fig. 3. The functions of the power supply kept under the control of the chip are managed through the network. The chip turns on and off the high voltage power supply and sets the output high voltage. The chip detects the short circuit of the output high voltage and controls its recovery. The chip also monitors the output current. Most functions of the high voltage power supply being brought under the control of the Neuron chip, the functions of the power supply are managed via the network.

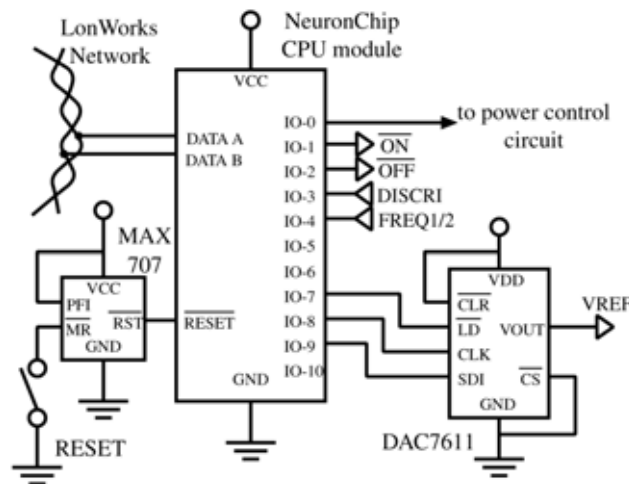

Fig3 Interface circuit between neuron chip and high voltage power supply

3.3. Output High Voltage

The high voltage supply includes a 12-bit digital-to-analog converter under the control of the Neuron chip. The reference voltage being generated by the converter, the output high voltage can be assigned through the network.

3. 4. Recovery from Feedback Breakdown

The VCO voltage, being the output of the error amplifier, is applied to the input of the VCO, controlling the driving frequency of the carrier. A frequency flip is produced by deviation of the VCO voltage from its normal range. This deviation is detected by a voltage comparator LTC1440, interrupting the Neuron chip. Once awakened, the Neuron chip detects the breakdown of the feedback and reports the detection thought the network, which helps to fix the cause of the breakdown. The Neuron chip, following instructions received from the network, manages recovery from the breakdown, where firstly the reference voltage is reset, which initializes the driving frequency, and secondly the chip increases the reference voltage to a prescribed value, restoring the output high voltage.

3. 5. Current Monitor

Once the output high voltage is assigned, the frequency at which the transformer is driven depends on load. The load shifts the driving frequency. It can be assumed at the first approximation that the output high voltage being specified, the feedback adjusts the driving frequency so as to keep fixed in the amplitude ratio. It is equivalent to assume that the feedback makes the amplitude ratio independent of the magnitude of the load, and that the magnitude of the load shifts the frequency so as to afford the fixed amplitude ratio.

The VCO outputs the driving frequency on a square wave, thus a simple logic circuit enables the chip to count pulses. The driving frequency, obtained by counting pulses over a fixed time interval, allows calculating the magnitude of the load based on the shift of the driving frequency.

4. Acknowledgments

We are indebted to the people engaged in development of ceramic transformer at Material Development Center, NEC Corporation for providing their newest ceramic transformers, and also indebted to Mr. Atsusi Ochi at NEC Corporation for continuous encouragement.

References

- [1] Y. Shikaze, M. Imori, H. Fuke, H. Matsumoto, and T. Taniguchi, A High-Voltage Power Supply Operating under a Magnetic Field, IEEE Transactions on Nuclear Science, Volume: 48, Jun 2001 pp. 535-540
- [2] M. Imori, T. Taniguchi, and H. Matsumoto, Performance of a Photomultiplier High Voltage Power Supply Incorporating a Piezoelectric Ceramic Transformer, IEEE Transactions on Nuclear Science, Volume: 47, Dec. 2000 pp. 2045-2049
- [3] M. Imori, T. Taniguchi, and H. Matsumoto, A Photomultiplier High-Voltage Power Supply Incorporating a Ceramic Transformer Driven by Frequency Modulation, IEEE Transactions on Nuclear Science, Volume: 45, June 1998 pp. 777-781
- [4] M. Imori, T. Taniguchi, H. Matsumoto, and T. Sakai, A Photomultiplier High Voltage Power Supply Incorporating a Piezoelectric Ceramic Transformer, IEEE Transactions on Nuclear Science, Volume: 43, June 1996 pp. 1427-1431
- [5] S. Kawasima, O. Ohnishi, H. Hakamata et. al., Third Order Longitudinal Mode Piezoelectric Ceramic Transformer and Its Application to High-Voltage Power Inverter, IEEE Ultrasonic Sympo., Nov., 1994, Cannes, France. pp.525-530.
- [6] O. Onishi, Y. Sasaki, T. Zaitzu, et. al., Piezoelectric Ceramic Transformer for Power Supply Operating in Thickness Extensional Vibration Mode, IEICE Trans. Fundamentals. Vol. E77-A, No. 12 December 1994. pp. 2098-2105.
- [7] T. Zaitzu, T. Inoue, O. Onishi and A. Iwatani, 2 M Hz Power Converter with Piezoelectric Transformer, INTELEC'92 Proc., pp.430-437, Oct. 1992..
- [8] C. Y. Lin and F. C. Lee, Design of Piezoelectric Transformer Converters Using Single-ended Topologies, 1994 VPEC Seminar Proceedings, pp.107-112.