

High-Efficiency X Band GaN Power Amplifier for Small Satellite Downlink System

Hiromi WATANABE¹, Osman CEYLAN³, Hirobumi SAITO², Atshushi TOMIKI²,

Hitoshi NUNOMURA⁴, Osamu SHIGETA⁴, Naohiko IWAKIRI², Takahiko SHINKE⁵, Tomoya FUKAMI¹

¹Department of Electrical Engineering and Information Systems, The University of Tokyo, Japan,

²Japan Aerospace Exploration Agency, Japan,

³Faculty of Electrical and Electronic Engineering, Istanbul Technical University, Turkey,

⁴AI Electronics Ltd., Japan, ⁵Addnics corp., Japan

Abstract — A high-speed downlink communication system is required to meet various applications for small satellites. The purpose of this research is to develop a high-data-rate (typically over 300Mbps) communication system. Generally, the operation at nonlinear region provides high efficiency for a RF power amplifier. However the amplitude-phase modulated signal, which is an efficient scheme in term of frequency band, requires high linearity. In order to amplify amplitude-phase modulated signal for high data rate, a 2W X Band GaN-HEMT power amplifier and digital pre-distortion technique were developed. In this paper measurements and simulations of the system are presented.

Index Terms — small satellite, downlink, X band, GaN-HEMT PA, digital pre-distortion.

I. INTRODUCTION

In a satellite communication system, main limitations are down link capabilities as well as sensing capabilities. Recent earth observations such as optical imaging and SAR imaging by satellites require higher spatial resolutions and more image data. This means that the down link data volume should be increased. Recently technologies of small satellites have been so matured that many earth observation missions are proposed [1]. However, it is true that nano/small satellite missions still have many limitations of satellite functions compared to large satellites.

The purpose of this research is to develop a high-data-rate (typically over 300Mbps) communication system which can be applicable to small satellites of 50 kg class in LEO (Low Earth Orbit). System will be demonstrated on orbit by “Hodoyoshi” small Satellite project, scheduled to be launched in within a few years [2].

A typical small satellite with 50kg can generate only as small as power of around 100W as total and can distribute roughly 20W. This is a power constraint for a high-data-rate communication system for small satellites. Several hundred Mbps down link system on conventional large satellite consume one or more hundreds watt.

In this project, it has been developing the communication subsystem both for the flight hardware as well as the ground

system, paying attention to reduce the DC power consumption and the mass of onboard instruments.

Section II describes outline of our novel high-data-rate down link system for nano/small satellites and other conventional downlink systems. In section III, it is presented that developed novel GaN HEMT X-band power amplifier. In section IV, the information is given about pre-distortion technique and measurement results. Section V shows the result of total dose testing for space qualification.

II. TRANSMITTER SYSTEM

One way to increase the down link data volume is to use data relay satellites. In this expensive scheme, a long visible time compensates its relatively low bit rate for long communication range between geo-synchronous orbit and LEO. Therefore, a cost-effective approach to increase the down link data volume seems to increase a data rate of downlink to an earth station which has a short visible time around 10 minutes. Fig.1 shows down link data rates of LEO satellites and their mass [3]. The figure indicates that down link data rates are proportional roughly to linear or square of satellite mass. This is because in general a downlink with a high data rate requires high DC power and large mass.

Conventional downlink systems of large satellites have capability of hundreds Mbps and in most cases they utilize X band (8025-8400MHz) for earth observation. The maximum bandwidth is 375MHz and in most cases a convolution coding with $r=1/2$ is applied. Therefore multi phase-shift-keying and amplitude-phase modulation are necessary to achieve higher bit rates than 300 Mbps. These modulations, however, are sensitive to nonlinear distortion of RF power amplifiers (PA). RF PAs have to be operated in linear region, which causes reduction of power efficiency. Also they require digital processing circuits with several hundred MHz clock. Fig.2 shows power consumptions as a function of data bit rate for onboard X-band transmitters with high data rates. Their power consumptions increase as the data bit rates increase with bandwidth-effective modulations.

TABLE I
System requirements

Center frequency	8.16 GHz
Band width	150 MHz
Modulation scheme	QPSK, 16QAM
Mod. symbol rate	10 Msps, 100 Msps
Avg. RF power	33 dBm (2W)
DC power consumption	< 20 W

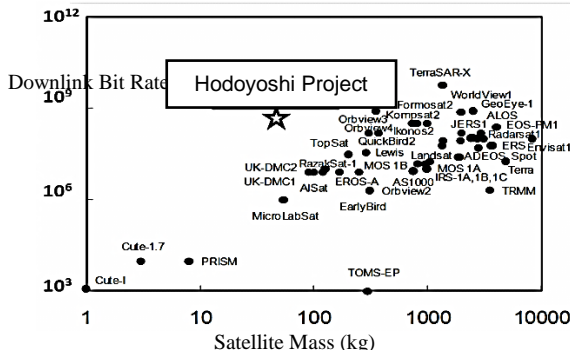

Fig.1 Down link bit rate vs. satellite mass for low earth orbit. ★ denotes presented novel technology.

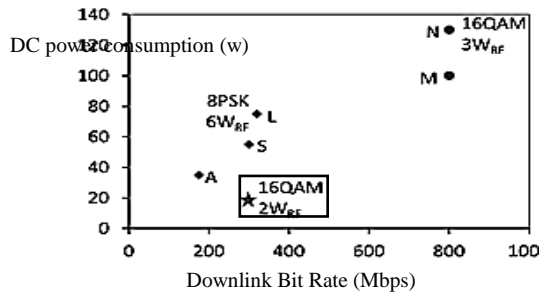

Fig.2 DC power consumption vs. data bit rate for onboard high-data-rate transmitter. ◆ and ● correspond to conventional transmitters with 8PSK and 16QAM, respectively. ★ denotes novel transmitter with 16QAM. RF power levels are also indicated.

Taking into account the matters described above, final system requirements was determined as shown in Table I.

III. SiC GAN HEMT X-BAND POWER AMPLIFIER

The GaN transistor has some advantages for space applications such as better heat dissipation, smaller size etc. Therefore, in PA design, die package bare GaN HEMT transistor was used. Triquint TFG2023-01 GaN transistor was preferred for this project. The nonlinear EEHEMT based model (GaN on SiC Process) of the transistor which was supported by company, used [4] at AWR Microwave Office for computer aided design of the amplifier. All transmission lines were modeled on electromagnetic solver of the software tool with the frequency that including third harmonics frequency to increase accuracy. Design contains two different circuit boards: Transistor mounted substrate (LTCC) and

input/output circuit substrate (Figure 3). Two substrates are connected to each other by wire bonds.

Additionally, designed novel power amplifier was optimized for nano/small satellites: Smaller package design, high PAE (Power Added efficiency) and optimization for pre-distortion technique.

GaN HEMT class AB power amplifier (Fig.4) designed to meet requirements is shown in Table 2. The symbol rate is 100Msps and the effective frequency bandwidth is about 150MHz (roll off coefficient is 0.5), which is just 1.8% of the carrier frequency 8.16 GHz. The frequency dependency of Gain characteristics shown in Fig.5 are by less than 1dB while the nonlinearities are by 2-3 dB in terms of compression power level.

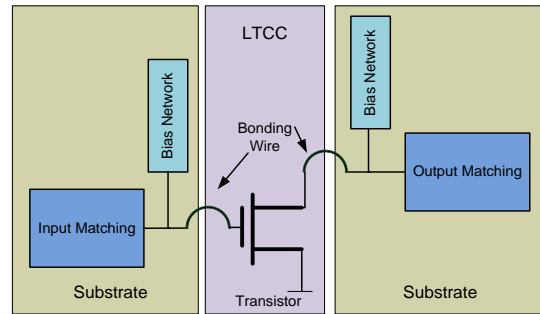

Fig.3 Structure of the Circuit Layout

A Phase shift characteristic of Fig.5 shows that phase shift is less than 7 degrees over the entire frequency range. This value is about 1/3 to 1/2 for the value of a conventional GaAs FET power amplifier [5]. As a result, this power amplifier can be used in smaller OBO (Output Back Off) point.

TABLE II
Specifications of GaN-HEMT class AB power amplifier

Drain voltage	28 V
Quiescent current	125 mA
Class	AB
Operating frequency	8.15 - 8.35 GHz
Avg. output power	34 dBm
Size	33.6×28.5×9 mm ³

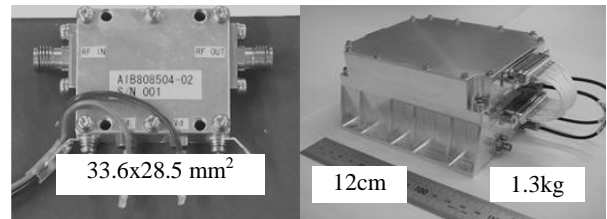

Fig.4 Photograph of PA (left) and transmitter (right)

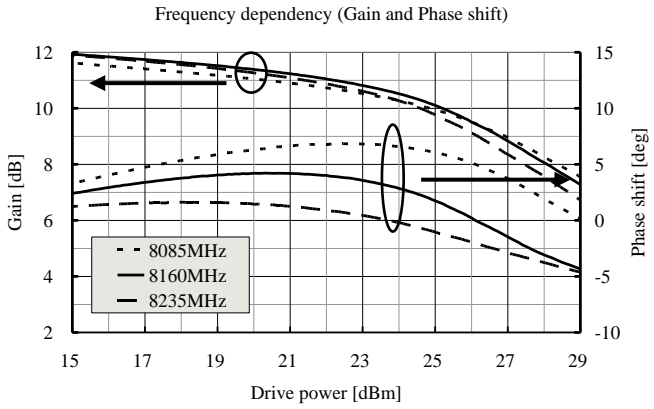

Fig.5 Frequency characteristics of power amplifier (measurement)

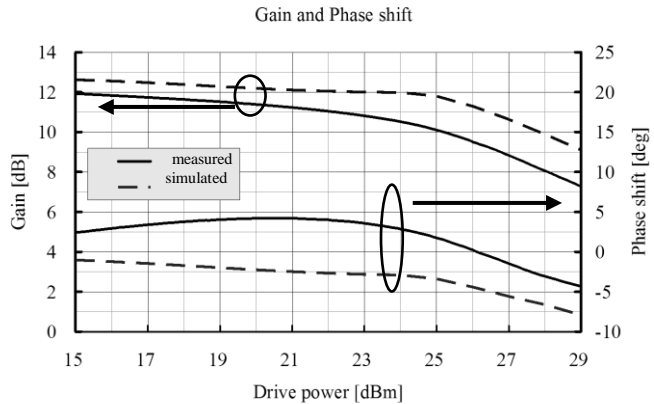

Fig.6 Comparison of simulation and measurement (Gain and Phase shift)

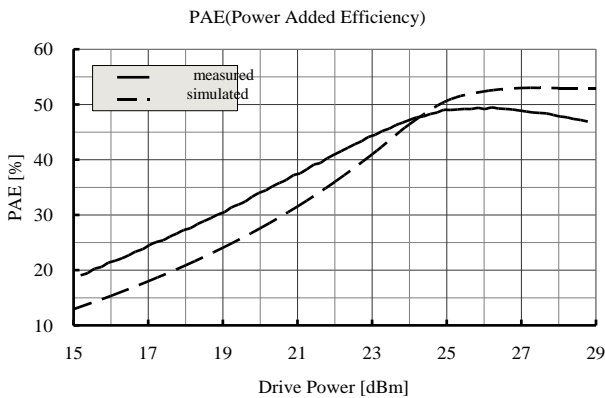

Fig.7 Comparison of simulation and measurement (PAE)

IV. 16QAM DEMODULATION AND PRE-DISTORTION TECHNIQUE

Figure 9 shows the constellation plot of the transmitter EM (Engineering Model) that has new PA (Fig.4). Its weight is 1.3kg and size is 12x12x7 cm³, including digital part. EVM (Error Vector Magnitude) is measured to be 12.8% rms at OBO 3dB.

Pre-distortion is a technique that improves EVM using distorted baseband signals [6]. This technique is new technology in small satellite communication, because it

requires large amount of computation. An optimized pre-distortion technique is being developed for small satellites (Figure 8). In order to decrease amount of computation, gradual saturation characteristics and less frequency dependency are required. Considering APD (Average Power Distribution) of 16QAM signal, the new PA has enough power between P1dB and saturation power, and in spite of 150MHz wide BW, its frequency dependency is measured to be as low as 1dB at maximum as shown in Fig.5. As a result, Pre-distortion will improve EVM easily.

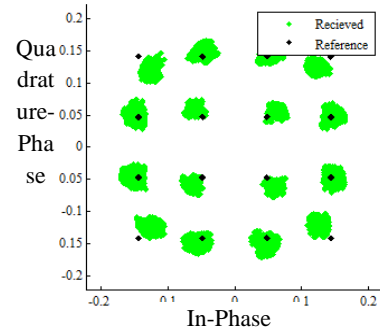

Fig.9 Constellation diagram
100Mbps, W/O noise, 199992 symbols, W/O pre-distortion

V. SPACE QUALIFICATION

As one of space environment tests, we performed total ionization test for the GaN amplifiers. This GaN amplifier will be applied to small earth observation satellites for high data rate down links. The orbits are sun-synchronized orbit with altitude of 500-800km. Total ionization doses are expected to be 20k rad for five years mission assuming shield of aluminum 2mm thickness. The GaN devices will be powered on only when data are down linked to the ground station for less than a hour per day. We irradiated 20k rad to a GaN amplifier module in one hour at a Co 60 radiation facility. The GaN amplifier is not powered on during the test to simulate our operation condition in space. Characteristics of input-output power relation and power-additive efficiency do not change with power accuracy of 0.1dB between before/after the radiation tests. This test shows our GaN is tolerant for the total ionization doze.

VI. CONCLUSION

This research has focused on a power efficient X-band downlink system with higher than 300Mbps data rate. Space conditions and satellite restrictions were considered during the design. In order to achieve both the signal quality and power saving, Class AB, X Band, GaN-HEMT power amplifier was designed and digital pre-distortion technique was developed. Engineering model of the system was tested under space conditions successfully and almost ready to use in a small satellite.

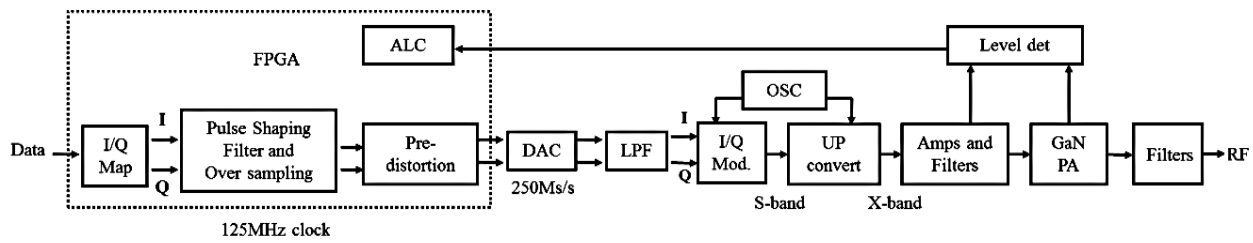

Fig.8 Block diagram of transmitter system (Engineering Model)

REFERENCES

- [1] H. Saito, "Small satellite REIMEI for aurora observation -five years orbit-," *IEICE Technical Report SANE2010-96*, Oct. 2010.
- [2] Shinichi Nakasuka, "From Education to Practical Use of Nano-satellites - Japanese University Challenge towards Low Cost Space Utilization -", *8th IAA Symposium on Small Satellite for Earth Observation*, Berlin, April. 2011.
- [3] Morio Toyoshima, Yozo Shoji, Yoshihisa Takayama and Takashi Maehata, "Log-likelihood coherent optical receiver -High-speed ADCless Architecture -," *IEICE Technical report* vol.110, No.46, pp.19-23, 2010.
- [4] TriQunit EEHEMT model Implemented in ADS and AWR for TQT 0.25 um 3MI GaN on SiC Process 1.25mm Discrete FET, *Application note*, 12/04/2009, TriQunit
- [5] Hirobumi Saito, Naohiko Iwakiri, Atsushi Tomiki, Takahide Mizuno, Hiromi Watanabe, Tomoya Fukami, Osamu Shigeta, Hitoshi Nunomura, Yasuaki Kanda, Kaname Kojima, Takahiro Shinke, and Toshiki Kumazawa, "HIGH-SPEED DOWNLINK COMMUNICATIONS WITH HUNDREDS Mbps FROM 50kg CLASS SMALL SATELLITES", *63rd INTERNATIONAL ASTRONAUTICAL CONGRESS (IAC2012)*, Naples, Italy, Oct. 2012.
- [6] E. Casini, R. De Gaudenzi and A. Ginesi, "DVB-S2 modem algorithms design and performance over typical satellite channels", *International Journal of Satellite Communications and Networking* vol.22, pp.281-318, 2004.