

HII/L2 Mission Cryogenic System

By

Masayuki HIRABAYASHI*, Makoto KYOYA*, Masahide MURAKAMI†
and Toshio MATSUMOTO‡

(November 1, 2000)

Abstract: The HII/L2 mission (SPICA) is a future mission to launch a large infrared observatory to the L2 orbit by an H-IIA rocket. A unique feature of its cryogenic system is a “warm launch” system using radiative cooling and mechanical cooling in orbit to cool down its detectors and mirrors to 4.5K. By adopting this system, we can remove the heavy vacuum shell and the helium tank needed for traditional cryostats, and reduce the weight of the spacecraft dramatically.

1. INTRODUCTION

The great success of *the Infrared Astronomical Satellite* (IRAS, Neugebauer et al. 1984) opened a new era of infrared astronomy. After IRAS, the Cosmic Background Explorer (COBE, Boggess et al. 1992) and *the Infrared Space Observatory* (ISO, Kessler et al. 1996) extended the possibility of the space infrared astronomy.

In Japan, we made the first step by *the Infrared Telescope in Space* (IRTS, Murakami et al. 1996), which was a small infrared survey mission, and now, we are developing a new survey mission, ASTRO-F/IRIS (Infrared Imaging Surveyor, Murakami et al. 1998), which is planned to be launched in 2004. The ASTRO-F has much better sensitivity and spatial resolution than those of IRAS, however there has been significant scientific importance of an observatory-type mission with a larger aperture ($\sim \phi 4\text{m}$) cooled telescope for mid- and far-infrared astronomy.

In order to achieve such a large cooled telescope mission, there are many technical difficulties in the conventional helium cryostat design.

1. The aperture size of the telescope is limited by the size of the helium tank and the vacuum shell.
2. The mission lifetime is limited by the amount of the liquid helium.

* Sumitomo Heavy Industries, Ltd. 5-8 Soubiraki-cho, Niihama, Ehime 792-8588, Japan;
msy_hirabayashi@shi.co.jp

† Institute of Engineering Mechanics and Systems, University of Tsukuba, Tennodai 1-1-1, Tsukuba, Ibaraki, 305-8573 Japan

‡ Institute of Space and Astronautical Science, 3-1-1 Yoshinodai, Sagami-hara, Kanagawa 229-8510, Japan

3. Observations with long integration time are difficult due to the avoidance from the sun and earth radiation.

Thus, the conclusion is that we have to develop a totally new cryogenic system for large aperture cooled telescope missions.

2. CRYOGENIC SYSTEM DESIGN

2.1 L2 Orbit

It is critical for infrared astronomical satellites to avoid the radiation both from the sun and from the earth to minimize the heat load. For this reason, the solar-synchronous orbit was chosen for IRAS, COBE, and ASTRO-F. Although the solar-synchronous orbit is suitable for survey missions, it is not for observatory-type missions, since observations with long integration times are very difficult in such an orbit to avoid the radiation from the earth. It leads us to the second Sun-Earth Lagrangian liberation point (L2) as an orbit for the observatory-type infrared mission.

Another advantage of the L2 orbit is that the apparent size of the earth becomes small ($\sim 30'$), and all of the heat sources (Sun, Earth, Moon) are in the same direction. Thus, it is easy to shield the telescope from the heat sources. A preliminary estimation shows that the radiative cooling if appropriately designed can cool down the telescope below 15 K.

2.2 System Design

A new concept for the HII/L2 cryogenic system is a “warm-launch” approach, which means the telescope and the focal plane instruments (FPI) are warm when it is launched, but are cooled in orbit. The telescope and the FPI are cooled by radiation to the deep space and by the mechanical coolers. Because of this system, we do not need to launch a large and heavy vacuum vessel, and as a result, we can launch a larger diameter cooled telescope that can never be launched with a conventional cryostat.

Figure 1 shows a schematic drawing of the cryogenic system and Figure 2 shows a cutaway view of the cryogenic system. The FPI and the primary mirror are attached on the Instrument Bay, and both are cooled with a 4.5 K mechanical cooler. Stressed Ge:Ga detectors are installed in the FPI, however independently cooled with a 1.7K mechanical cooler. The Instrumental Bay is supported by a low thermal conductive structure from the shield #3. On the other hand, the shield #3 is supported from the Bus Module by another low thermal conductive structure. The Black Baffle and the Telescope Shell surround the Primary Mirror to cut the radiative heat input.

In order to cut the radiative heat from the hotter stages to the colder stages, there are three radiation shields, which are called shield #1 to #3 from inner to outer. All the radiation shields are cooled by radiation to the deep space, and the radiators are located at the overlapped edges of each shield. Outside the shield #3 is the Sun Shield which protect the cryogenic system against the heat from the sun. In order to cool down the surface facing the sun, the MLI is attached to the sunshield, and the surface of the MLI is covered with high IR emissivity and low solar absorptance material.

The specification of the cryogenic system is shown in Table 1.

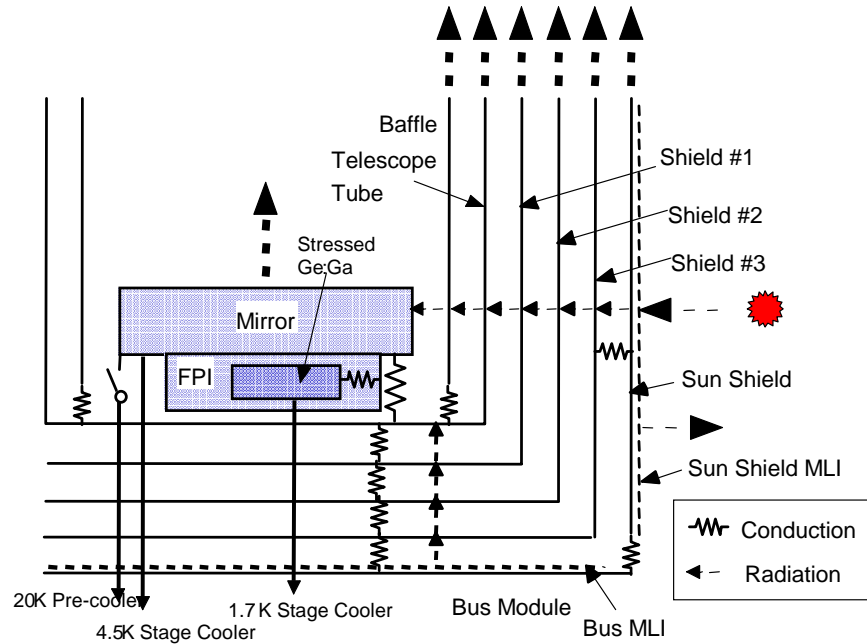

Fig. 1: Schematic drawing of the cryogenic system

Table 1: Specifications for HII/L2 cryogenic system

Parameter	Specifications
Mirror diameter	3.5 m
Mirror temperature in space	4.5 K
Cooling power of mechanical coolers	4.5 K stage for Si:As Detector: < 6 mW @ 6 K 1.7 K stage for Ge:Ga Detector: < a few mW @ 1.7 K
Power consumption of mechanical cooler	1.7 K Cooling System: 300 W 4.5 K Cooling System: 200 W (Mirror Pre-cooling System: 100 W)

2.3 Mechanical Cooler

As described above, the HII/L2 cryogenic system adopts mechanical coolers to cool down the FPI and the telescope system in the Instrument Bay. The present mechanical cooling system is summarized in Table 2. The Instrument Bay is cooled down to 4.5 K by a 2 stage Stirling cooler with a ⁴He Joule-Thomson valve. The stressed Ge:Ga detector, which is one of the FPI instruments, is independently cooled down to 1.7K by a 2 stage Stirling cooler with a ³He Joule-Thomson valve. The third cooler is used to pre-cool the Instrument Bay to shorten the cooling time. The detailed design of the mechanical coolers is described in a separate paper (Narasaki et al. 2000).

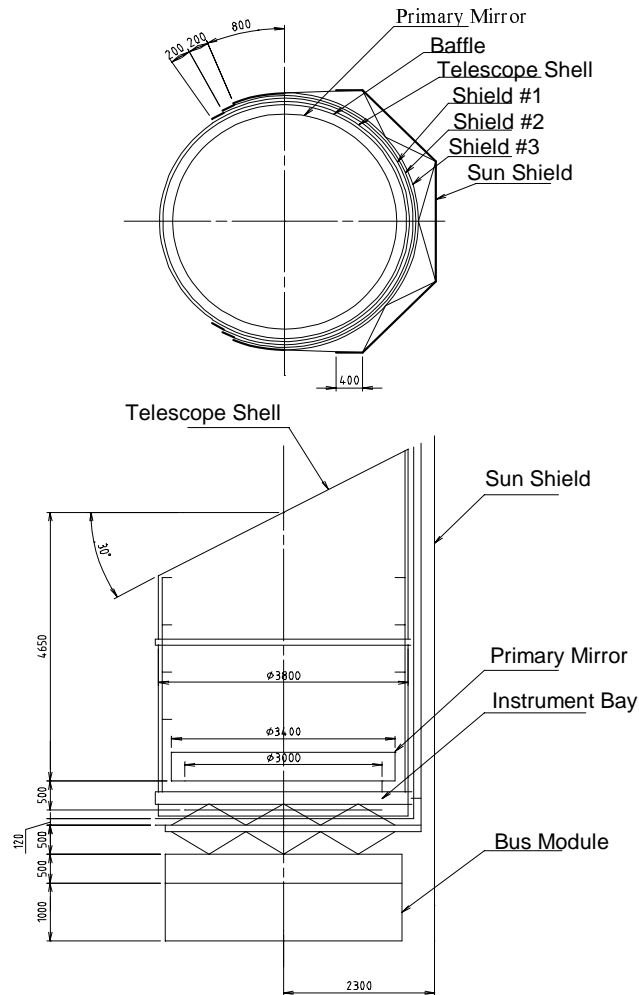

Fig. 2: Cutaway view of the cryogenic system

3. THERMAL ANALYSIS

3.1 Steady State Analysis

The thermal analysis of the HII/L2 cryogenic system was performed using a conventional thermal network analysis method. The analytical condition is shown in Table 3. As the spacecraft stays at the L2 point, the main heat load comes only from the sun; the heat from the earth is negligible. The Mirror and the FPI temperature were fixed at 4.5 K in order to estimate the heat load input to the 4.5 K stage.

The result of the steady state analysis is shown in Figure 3. The total heat load into the 4.5 K stage is 22.5 mW, which value is within the cooling power of the mechanical cooler at 4.5 K.

This analysis model was built for a preliminary feasibility study and there are some points to be improved;

1. Each thermal stage is modeled as one node. More detailed modeling of the thermal stages

Table 2: Mechanical coolers of the HII/L2 cryogenic system

Purpose	Pre-cooling of 4.5 K stage	Cooling of 4.5 K stage (Telescope, Si:As detector)	Cooling of 1.7 K stage (Stressed Ge:Ga detector)
Component	2-stage Stirling Cycle Cooler	⁴ He JT + 2-stage Stirling Cycle Cooler	³ He JT + 2-stage Stirling Cycle Cooler
Number of sets	1	1	1
Initial Operation (Transient Cooling)	ON	OFF	OFF
Steady State Operation	OFF	ON	ON
Net Power Consumption	100 W	200 W	300 W

to estimate the effects of the temperature gradient in each thermal shield.

2. The Instrument Bay temperature is treated as a fixed temperature boundary. We are establishing the temperature vs cooling power curve from the performance tests of the mechanical cooler. By applying this curve, we will be able to estimate the temperature of the Instrument Bay, more precisely.

Table 3: Thermal analysis conditions

Temperature Boundary	
Deep Space	3 K
Mirror, FPI	4.5 K
BUS Module	250 K (Conductive boundary)
Heat Load	
FPI	15 mW @4.5 K Stage (6 mW from Si:As 6K stage assumed) (1.7 K stage is independently cooled by another mechanical cooler)
Sun	1423 W m ⁻² (IR and the albedo from the earth and the moon are negligible)

3.2 Transient Analysis

In addition to the steady state analysis, the transient analysis was performed to estimate the necessary time to cooldown the mirror from the room temperature at launch to 4.5 K during observation. We assumed the mass distribution of the cryogenic system as shown in Table 4. In this transient analysis, the two cases were analyzed; one is with the pre-cooler for the 4.5

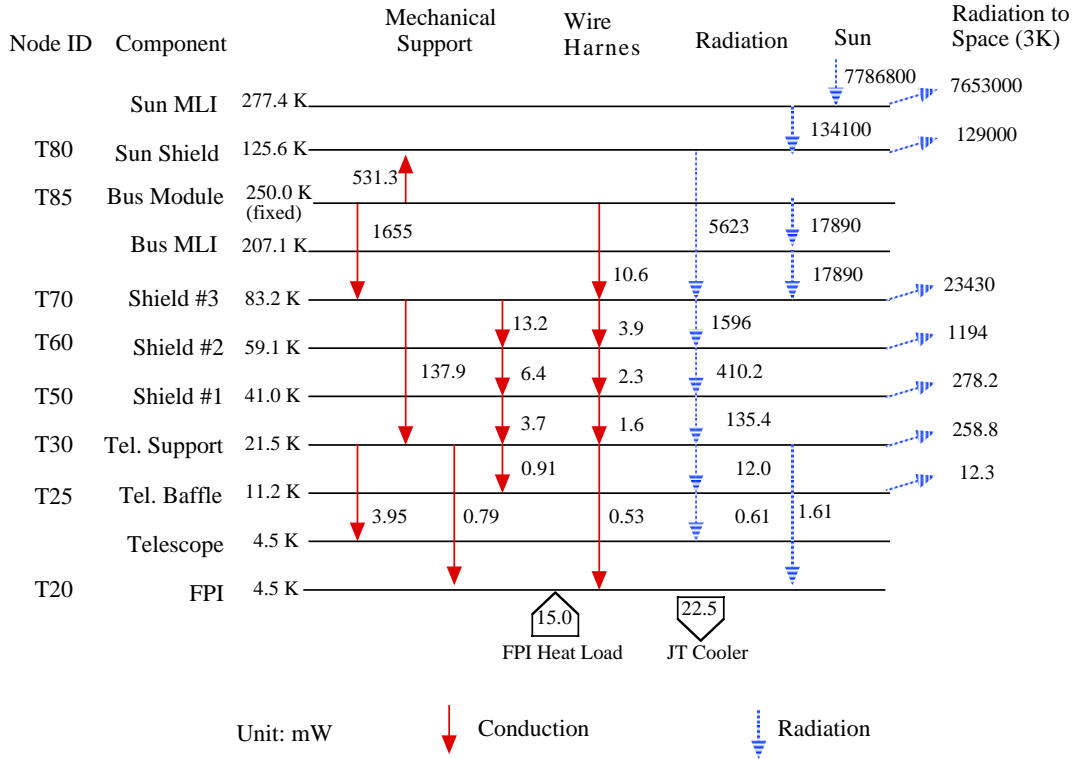

Fig. 3: Heat flow in the HII/L2 cryogenic system

K stage, and the other is without the pre-cooler. The results are shown in Figure 4 (with pre-cooler), and Figure 5 (without pre-cooler).

With the pre-cooler, it takes about 260 days to cool the FPI and the mirror from the room temperature to 4.5 K, on the other hand, it takes 850 days without the pre-cooler. Although the usage of the pre-cooler remarkably reduces the required cooling time, it is still too long compared to the estimated time for the spacecraft to reach the L2 point. Thus, an additional small helium cryostat just for the initial cooling of the 4.5 K stage is one of the candidates for solution.

Table 4: Assumed mass distribution in the analysis model

Element	Material	Mass (kg)
Primary Mirror	ULE Glass	565
Mirror Support	Aluminum Alloy	715
Focal Plane Instruments	Aluminum Alloy	300
Baffle/ Telescope Cylinder	Aluminum Alloy	250
Shield #1	Aluminum Alloy	130
Shield #2	Aluminum Alloy	135
Shield #3	Aluminum Alloy	138
Total		2233

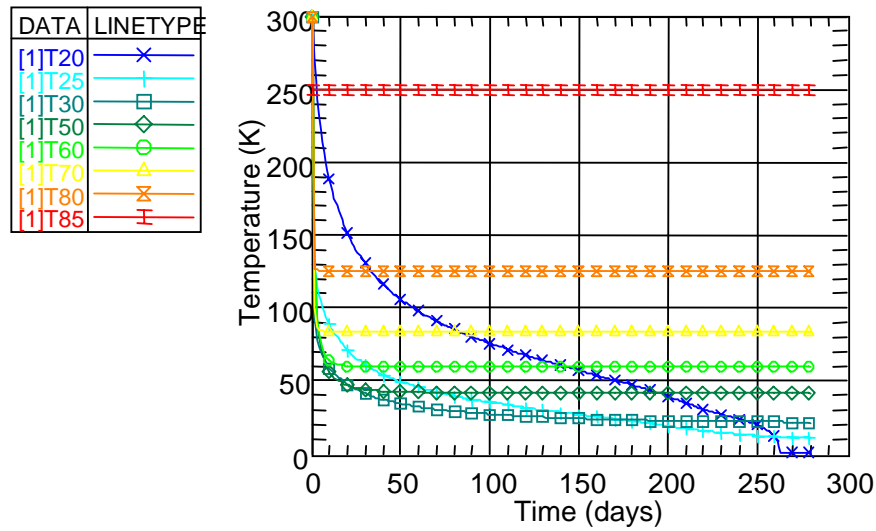

Fig. 4: Initial cooldown time for the HII/L2 cryogenic system with a 20 K cooler

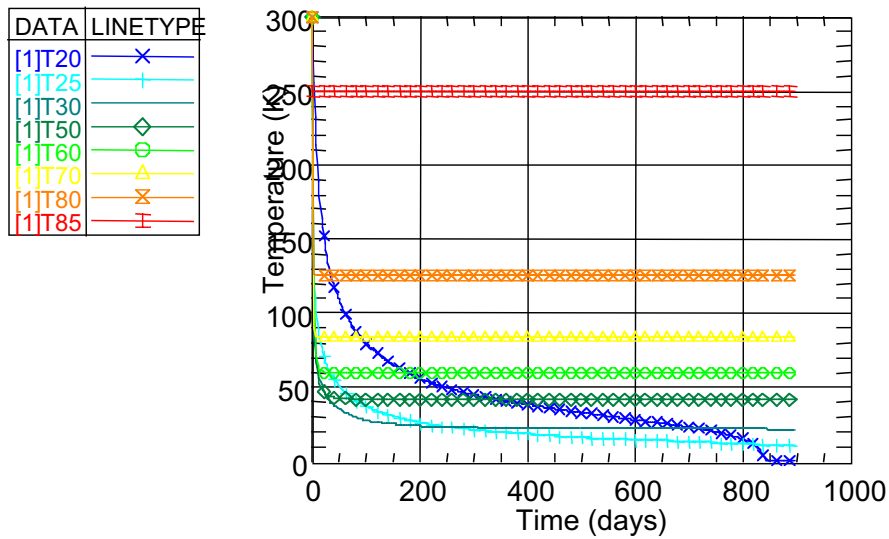

Fig. 5: Initial cooldown time for the HII/L2 cryogenic system without a 20 K cooler

4. CONCLUSION

The feasibility of the cryogen-free cryogenic system for the HII/L2 mission was discussed. The present design of the 4.5 K mechanical cooler system has enough cooling power for the heat load into the 4.5 K stage. The transient analysis showed that the initial cooldown time can be reduced by adopting a pre-cooler.

More detailed thermal analysis can be done by refining the model and by applying the results from the performance tests of the present mechanical coolers.

REFERENCES

- Boggess, N. W. et al., 1992, ApJ, 396, 420
Kessler, M. F. et al., 1996, A&A, 315, L27
Murakami, H. et al. 1996, PASJ, 48, L41
Murakami, H. et al. 1998, SPIE Proc. 3356, 22
Narasaki, K. et al. 2000, this volume
Neugebauer, G. et al., 1984, ApJ, 278, L1